

## DIRECT SYNTHESIS OF MULTI-WALLED AND SINGLE-WALLED CARBON NANOTUBES BY SPRAY-PYROLYSIS

L. P. Biró, Z. E. Horváth, A. A. Koós, Z. Osváth, Z. Vértesy, Al. Darabont<sup>a</sup>, K. Kertész<sup>a\*</sup>, C. Neamțu<sup>b</sup>, Zs. Sárközi<sup>a</sup>, L. Tapasztó<sup>a</sup>

Hungarian Academy of Sciences, Research Institute for Technical Physics and Materials Science, P.O. Box 49, H-1525, Budapest, Hungary

<sup>a</sup>Babeş-Bolyai University, Faculty of Physics, 1, Kogălniceanu St., Cluj-Napoca, 3400, Romania

<sup>b</sup>National Institute for Research and Development of Isotopic and Molecular Technologies, 71-103, Donath St., P.O. Box 700, Cluj-Napoca, 3400, Romania

In the present paper we report the simultaneous synthesis of single-walled carbon nanotubes (SWCNTs) and multi-walled carbon nanotubes (MWCNTs) by spray-pyrolysis, a type of chemical vapour deposition (CVD) method. The technical characteristics of the home-made experimental set-up are given. The synthesis involves the spray-pyrolysis of ferrocene ( $\text{Fe}(\text{C}_5\text{H}_5)_2$ ) in benzene ( $\text{C}_6\text{H}_6$ ) solution in Ar atmosphere. The effects of the following characteristic parameters of the spray-pyrolysis process were studied: the temperature in the reaction tube, the ferrocene concentration, and the flow-rate of the ferrocene-benzene solution. The obtained samples (carbonaceous material deposited on the walls of the reaction tube) were analysed by Transmission Electron Microscopy (TEM) and Scanning Tunneling Microscopy (STM). From the obtained TEM and STM images we concluded that the best values of the studied parameters, regarding both the quality and quantity of the as grown carbon nanotubes, are: (i) ferrocene concentration - 3 g ferrocene in 50 ml benzene; (ii) flow-rate of the ferrocene-benzene solution - 1 ml/min; (iii) reaction tube temperature in the 875–925 °C range.

(Received July 14, 2003; accepted July 31, 2003)

*Keywords:* Carbon nanotubes, Spray-pyrolysis, Ferrocene catalyst, TEM, STM

### 1. Introduction

In the past decade since the first observation by Iijima [1] of multi-walled carbon nanotubes (MWCNT) an explosive development took place in the field of carbon nanotube (CNT) science based on efforts of scientists from various fields of physics, chemistry and materials science. The increase of the interest for these nanostructures is related to their exciting electronic and mechanical properties [2, 3,4]. The three main directions envisaged for practical applications of carbon nanotubes are: a) nanoelectronics [5]; b) field emission based devices and flat panel [6]; c) carbon nanotube reinforced composite materials [7]. The recent years brought impressive breakthroughs towards practical applications in the field of nanoelectronics: logic gates assembled from nanowires [8] and carbon nanotube based logic circuits [9] and in the field of field emission devices: the achievement of a lighting element with cylindrical geometry [10].

No realistic attempt to exploit the potential benefits of the practical applications of carbon nanotubes is possible without the ability of producing large amounts of carbon nanotubes at commercially viable prices. In the last decade three main methods were used for the production of carbon nanotubes, two high temperature methods: the electric arc method [11] and the laser ablation

---

\* Corresponding author: sarkozi@phys.ubbcluj.ro

method [12], and a lower temperature method, the chemical vapour deposition method (CVD), based on the decomposition of hydrocarbons in the presence of transition metal catalysts [13]. The high temperature methods produce CNTs with better structural quality, but the feasibility of their industrial up-scaling is questionable, and the price of the product is high. Several variations of the CVD method are suitable for industrial up-scaling and allow low cost production. The production price is strongly related with the amount of live labour needed to carry out the growth and the purification. Therefore, those methods are the most promising ones which do not need a catalyst synthesis step, like the spray-pyrolysis method [14], and necessitate a minimal of purification after growth.

The major advantage of the spray-pyrolysis method consists in the direct and continuous generation of catalytic particles throughout the entire growth cycle. The generation of the fresh catalytic particles prevents the formation of large amounts of amorphous carbon – which would necessitate tedious purification steps – taking place usually after the complete enclosure in nanotubes or graphitic nanoparticles of the catalytic particles existing at the beginning of the reaction. On the other hand, as the catalyst particles are generated in-situ, the fine tuning of the spray and temperature parameters is of paramount importance to fully benefit from the advantages of the method. In the present paper we investigated the influence of various parameters as: temperature, ferrocene concentration and ferrocene in benzene solution flow-rate on the quality and quantity of the nanotubes grown by spray-pyrolysis.

## 2. Experiment

### 2.1. Experimental setup

The scheme of our home-made experimental spray-pyrolysis set-up used for the synthesis of carbon nanotubes is represented in Fig. 1.

One of the most important components of this experimental set-up is the sprayer (atomiser). The scheme of this sprayer is given in Fig. 2. The sprayer consists of a pyrex nozzle (capillary end of the inner tube) having an inner diameter of 0.65 mm, and an outer pyrex tube which has an exit diameter of 2 mm. This outer tube directs the carrier gas-flow (Ar) around the nozzle.

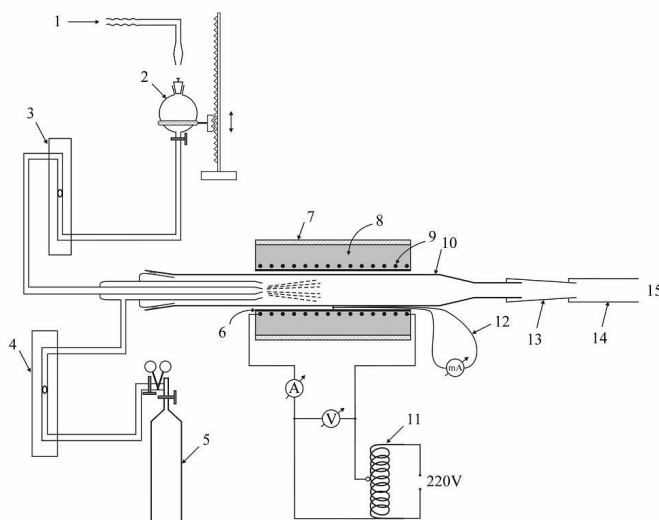

Fig. 1. Scheme of the home-made spray-pyrolysis set-up for the synthesis of carbon nanotubes. 1-Ar gas inlet; 2-container for the solution of ferrocene in benzene; 3-solution flow-meter; 4- Ar gas flow-meter; 5- Ar gas cylinder; 6- alumina tube; 7-porcelaine tube; 8- thermal and electrical insulation; 9- heating element; 10- quartz tube; 11- autotransformer; 12- Pt-Pt(Rh) thermocouple; 13- teflon tube; 14- rubber tubing; 15- outlet to the air.

The inner tube of the sprayer is attached at one end to the solution (ferrocene dissolved in benzene) container. The other end of the nozzle is fixed to a quartz tube (reactor) by means of a polished glass-to-glass connection. The quartz tube has an inner diameter of 20 mm and it is placed in a 300 mm long electrical furnace. The quartz tube plays also the role of the support for reaction products which appear by pyrolytic decomposition of the starting materials (benzene and ferrocene). The used electrical furnace is able to assure a uniform temperature up to 1200 °C.

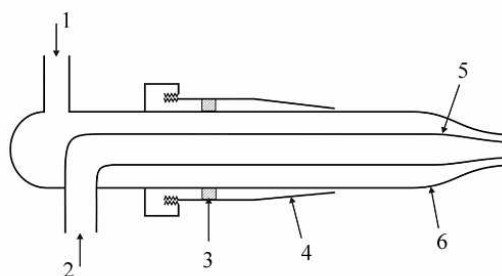

Fig. 2. Scheme of the sprayer (atomizer). 1-Ar-gas inlet; 2- solution inlet; 3-tightening; 4- polished glass-to-glass connection; 5,6-inner and outer pyrex tube.

## 2.2. Experimental procedure

The container is filled with the ferrocene in benzene solution of a given concentration. In the meantime the reactor is flushed with Ar gas in order to eliminate the oxygen from the reaction chamber, and is preheated to temperatures between 750 and 1000 °C by means of the electrical furnace. The Ar flow-rate is set at a desired value, than the ferrocene in benzene solution is released and pulverized into the sprayer by the Ar gas flowing around the nozzle. The solution flow-rate is adjusted at the desired value. The spraying time lasted usually between 30 and 120 minutes, depending on the solution flow-rate. The temperature of the furnace was maintained at the preset temperature for additional 15 min. in order to anneal the reaction products. After this step, the reactor was cooled gradually to room temperature. Numerous pyrolysis experiments were carried out exploring the effect of the furnace temperature, the ferrocene in benzene solution flow-rate and the concentration of ferrocene in benzene.

The summary of these experiments is given below in Table 1.

Controlling the values of these parameters, we tried to produce carbon nanotubes with good quality and in high percentage. The carbonaceous material deposited on walls of the quartz tube inside the furnace was collected and analysed by Transmission Electron Microscopy (TEM) and Scanning Tunneling Microscopy (STM).

The effect of catalyst (ferrocene) concentration in benzene was studied between 1.5 and 4.5 g ferrocene in 50 ml benzene, while the solution flow-rate, the Ar flow-rate and the temperature of the reactor were held at constant values (see Table 1).

The influence of the temperature of pyrolysis was investigated between 775 and 975 °C. In this case, the solution flow-rate, the Ar flow-rate and the ferrocene concentration in benzene had constant values.

We examined also the influence of the solution flow-rate in the 0.5–3 ml/min range, while the other three parameters were set to be constants.

## 3. Results

On the basis of TEM images it was possible to select those values of the investigated parameters at which we have obtained the best samples regarding the quality as well as the quantity of the carbon nanotubes. These values are: ~3 g ferrocene in 50 ml benzene catalyst concentration,

~1 ml/min solution flow-rate, 875–925°C temperature range. The Ar (carrier gas) flow-rate was unmodified, 500 l/h.

In Figs. 3–7, we present TEM and STM images of some characteristic samples.

Table 1. Parameters investigated for the studied samples.

Catalyst (ferrocene) concentration effect		Solution flow-rate effect		Pyrolysis temperature effect	
sample	other parameters: solution flow-rate $1\text{ ml/min}$ temperature $875^\circ\text{C}$ Ar gas flow-rate $500\text{ l/h}$	sample	other parameters: catalyst concentration $\frac{3\text{ g ferrocene}}{50\text{ ml benzene}}$ temperature $875^\circ\text{C}$ Ar gas flow-rate $500\text{ l/h}$	sample	other parameters: solution flow-rate $1\text{ ml/min}$ catalyst concentration $\frac{3\text{ g ferrocene}}{50\text{ ml benzene}}$ Ar gas flow-rate $500\text{ l/h}$
	catalyst quantity (g) in 50 ml benzene		solution flow-rate (ml/min)		temperature (°C)
S1	4.5	S6	0.5	S11	825
S2	1.5	S7	2	S12	925
S3	2.5	S8	1	S13	975
S4	3.5	S9	3	S15	775
S5	1.5	S10	0.5	S8	875

XRD measurements indicate that beside the carbon nanotubes, the main byproducts are Fe and  $\text{Fe}_3\text{C}$  particles. The samples also contain a small amount of amorphous carbon. In all cases it can be observed that the so obtained carbon nanotubes are filled partially by the catalyst. The mentioned byproducts can be eliminated by heating the samples in dilute nitric acid for several hours, than a heating in distilled water, and finally washing the sample several times with distilled water. The result of this purification process can be observed by the comparison of the TEM images given in Fig. 4 a) and b), for the sample S8. As it is seen, the purification process does not affect the catalysts encapsulated in the carbon nanotubes.

The STM images, like in Fig. 6, justify that beside the MWCNTs, in the obtained samples there are SWCNTs also, especially in the samples prepared at higher temperatures. Also a common feature obtained in the samples is the so-called CNT bundle, shown in Fig. 7, which consists of several parallelly placed, adhered CNTs.

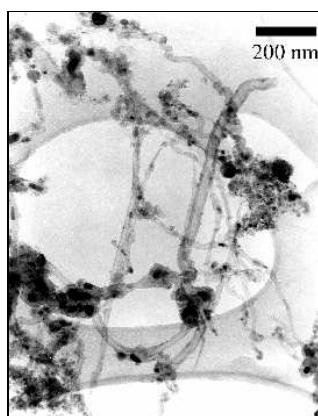
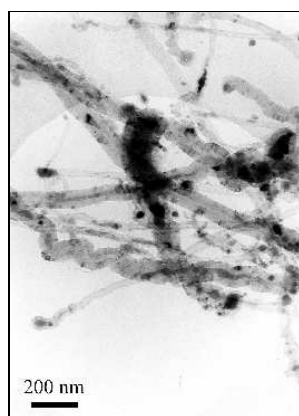
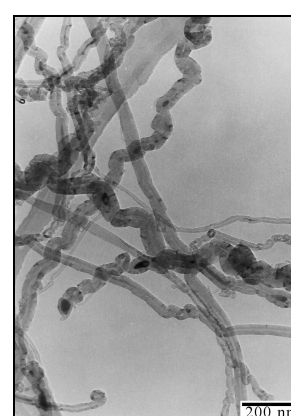

Fig. 3. Characteristic TEM image of sample S4.



a)



b)

Fig. 4. Characteristic TEM images of samples S8 a) before and b) after the purification treatment.

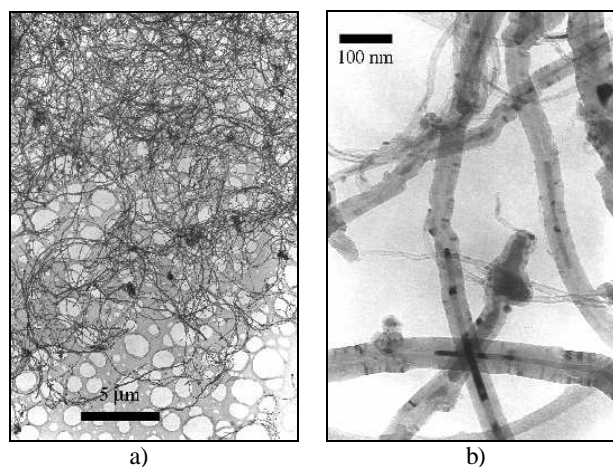

Fig. 5. Characteristic TEM images of sample S9 before the purification treatment.

#### 4. Discussion

The investigation of several parameters governing the growth of the nanotubes showed that by the careful tuning of these parameters the growth can be controlled and optimal conditions can be found, which allow the growth of a product constituted mainly of well aligned carbon nanotubes, with very little unwanted byproducts. By careful evaluation of a large number of TEM images, like in Fig. 5 b), using statistical procedures to find the characteristic nanotube diameters [15], it was possible to show that when using ferrocene concentrations of the order of 3 g/50 ml, in the temperature range of 850 – 950 °C, the diameter of the grown tubes shows a bimodal distribution (namely a gaussian distribution consisting of two peaks) as reported earlier by Singh et al. [16], with typical outer diameters in domain of 20 and 60 nm. This bimodal distribution vanishes by the decrease of the ferrocene concentration or by the increase of the growth temperature. It is found that with increasing growth temperature the maximum of the diameter distribution is shifted towards smaller diameters. In the samples grown at the highest temperatures used in the present work a small fraction of single-walled carbon nanotubes was found by careful STM examination, Fig. 6.

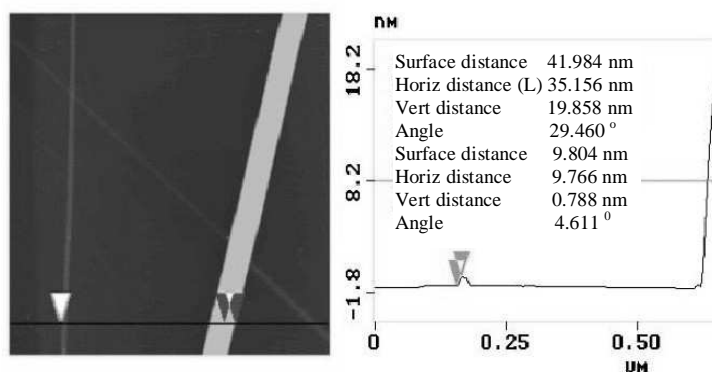

Fig. 6. STM image of a single-walled and a multi-walled carbon nanotube.

It has to be pointed out that the measured height values for these tubes believed to be SWCNTs is in the same range as the values measured on samples composed only from SWCNTs. Similar findings have been reported earlier by [17], however, in a subsequent experiment carried out by the Rice-group [18,19] the SWCNTs were not found. The possible explanation of these controversial findings might be the relatively small fraction of SWCNTs in the samples. On the other hand it has to be

emphasised that the growth of SWCNTs by the CVD method using heterogeneous catalysis [20] also necessitates temperatures around 1000 °C.

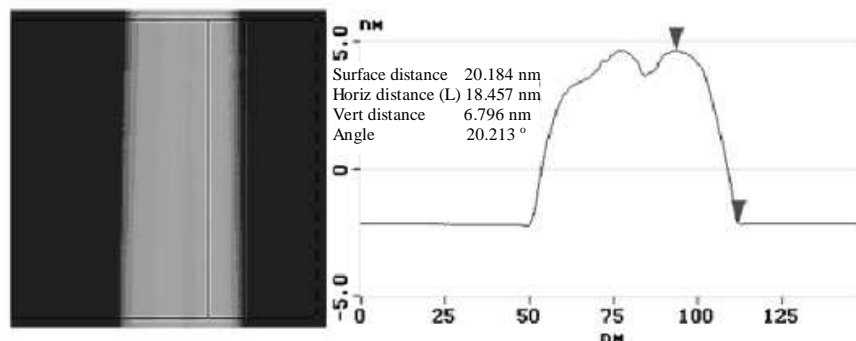

Fig. 7. STM image of a bundle of CNTs.

### Acknowledgements

The work in Romania was supported by the Sapientia Research Programs Institute in the framework of fellowships 822/2001 – K/513/2003.03.25, and in Hungary by OTKA through the grant nr. T 043685.

### References

- [1] S. Iijima, *Nature (London)* **354**, 56 (1991).
- [2] M. S. Dresselhaus, G. Dresselhaus, P. C. Eklund, *Science of Fullerenes and Carbon Nanostructures*, Academic Press, San Diego, 1996.
- [3] L. P. Biró, C. A. Bernardo, G. G. Tibbets, Ph. Lambin Eds., *Carbon Filaments and Carbon Nanotubes: Common Origins, Differing Applications*, Kluwer Academic Publishing House, Dordrecht, 2001.
- [4] M. S. Dresselhaus, G. Dresselhaus, Ph. Avouris Eds., *Carbon Nanotubes Synthesis, Structure, Properties, and Applications*, Springer Verlag, Berlin, 2001.
- [5] V. Derycke, R. Martel, J. Appenzeller, Ph. Avouris, *Nano Lett.* **9**, 453 (2001).
- [6] J-M. Bonard, Th. Stöckli, F. Maier, W. A. De Heer, A. Chatelain, J-P. Salvetat, L. Forró, *Phys. Rev. Lett.* **81**, 1441 (1998).
- [7] E. T. Thostenson, Z. Ren, Tsu-Wei Chou, *Comp. Sci. Technol.* **61**, 1899 (2001).
- [8] Y. Huang, X. Duan, Y. Cui, L. J. Lauhon, K-H. Kim, Ch. M. Lieber, *Science* **294**, 1313 (2001).
- [9] A. Bachtold, P. Hadley, T. Nakanishi, C. Dekker, *Science* **294**, 1317 (2001).
- [10] J-M. Bonard, Th. Stöckli, O. Noury, A. Chatelain, *Appl. Phys. Lett.* **78**, 2775 (2001).
- [11] T. W. Ebbesen, P. M. Ajayan, *Nature* **358**, 220 (1992).
- [12] A. Thess, R. Lee, P. Nikolaev, H. Dai, P. Petit, J. Robert, C. Xu, Y. H. Lee, S. G. Kim, A. G. Rinzler, D. T. Colbert, G. E. Scuseria, D. Tomanek, J. Fischer, R. E. Smalley, *Science* **273**, 483 (1996).
- [13] D. S. Bethune, C. H. Kiang, M. S. de Vries, G. Gorman, R. Savoy, J. Velazquez, R. Beyers, *Nature* **363**, 605 (1993).
- [14] R. Kamalakaran, M. Terrones, T. Seeger, Ph. Kohler-Redlich, M. Rühle, *Appl. Phys. Lett.* **77**, 3385 (2000).
- [15] L. Tapasztó, K. Kertész, Z. Vértesy, Z. E. Horváth, A. A. Koós, Z. Osváth, Zs. Sárközi, Al. Darabont, L. P. Biró, to be published elsewhere
- [16] Ch. Singh, M. S.P. Shaffer, A. H. Windle, *Carbon* **41**, 359 (2003).
- [17] H. M. Cheng, F. Li, X. Sun, S. D. M. Brown, M. A. Pineda, A. Marucci, G. Dresselhaus, M. S. Dresselhaus, *Chem. Phys. Lett.* **289**, 602 (1998).
- [18] R. Andrews, D. Jaques, A. M. Rao, F. Derbyshire, D. Qian, X. Fan, E. C. Dickey, J. Chen, *Chem. Phys. Lett.* **303**, 467 (1999)
- [19] Special section in *Chem. and Eng. News* **77**, 31 (1999).
- [20] J. F. Colomer, G. Bister, I. Willems, Z. Kónya, A. Fonseca, G. Van Tendeloo, J. B. Nagy, *Chem. Commun.* **14**, 1343 (1999).