

MAGNETIC HEADS FOR HIGH COERCIVITY RECORDING MEDIA

V. N. Samofalov^{*}, E. I. Il'yashenko^a, A. Ramstad^b, L.Z. Lub'yanuy, T.H. Johansen^c

National Technical University "Kharkov Polytechnical Institute", 21 Frunze St., 61002, Kharkov, Ukraine

^aMoscow State University, Vorob'evy Gori, 119899 Moscow, Russia

^bTandberg Storage, Kjelsåsveien 161, P.O. Box 196, Kjelsås, N-0411 Oslo, Norway

^cUniversity of Oslo, Department of Physics, Blindern, N-0316 Oslo, Norway

The application of high coercive storage media would increase density, reliability and lifetime for thermal decay of recording information. The systems of permanent magnets generating strong magnetic fields are proposed to create the heads for recording on high coercive media ($H_C = 5-15$ kOe). On the basis of calculations made for different magnet systems, the possibility of dense longitudinal and perpendicular recording was grounded.

(Received April 26, 2004; accepted June 22, 2004)

Keywords: Permanent magnet, Stray field, Demagnetization, Giant anisotropy, Coercive force

1. Introduction

At present, commercial application of high coercivity media for magnetic recording is complicated by the absence of recording heads capable to magnetize alternatively such high-coercive media. Finding a solution of the problem will allow to increase density and reliability of recording information [1,2,3]. In the present work, for longitudinal and perpendicular information recording on high coercive media, we propose to use strong stray fields occurring at the edges of charged magnet surfaces with giant magnet anisotropy [4]. It was shown that such fields are attained in the systems of hard magnetic materials based on rare-earth metals with uniaxial anisotropy field $H_K > 100$ kOe and coercive force $H_C > 2\pi M_S$ (M_S is the saturation magnetization of the magnet material). In Fig. 1a one of the magnet systems generating strong magnetic fields is shown to illustrate the recording principle. The longitudinal field component $H_x(x,y,z)$ is here given by

$$H_x = M_S \left[\ln \left[\frac{y+b+\sqrt{x^2+(y+b)^2+z^2}}{y-b+\sqrt{x^2+(y-b)^2+z^2}} \right]^2 \frac{y-b+\sqrt{(x+a)^2+(y-b)^2+z^2}}{y+b+\sqrt{(x+a)^2+(y+b)^2+z^2}} \frac{y-b+\sqrt{(x-a)^2+(y-b)^2+z^2}}{y+b+\sqrt{(x-a)^2+(y+b)^2+z^2}} \right] \quad (1)$$

Shown in Fig. 1b is a surface plot of the field $H_x(x,y)$ for the case $2b = a$, and $z = 0.01a$. As one sees, for points positioned near OY axis, the horizontal component of stray field takes large values $H_x \sim 20$ kOe, which is more than twice the magnet material induction value. With increasing distance from magnet surface, the component H_x decreases following to logarithmic law. The perpendicular component of the stray field H_z is limited in magnitude by $2\pi M_S$, which is seen from Fig. 2 showing $H_z(x)$ at $y = 0$ for $z = 0.01a, 0.1a$ and $0.3a$.

^{*} Corresponding author: Samofalov@kpi.kharkov.ua

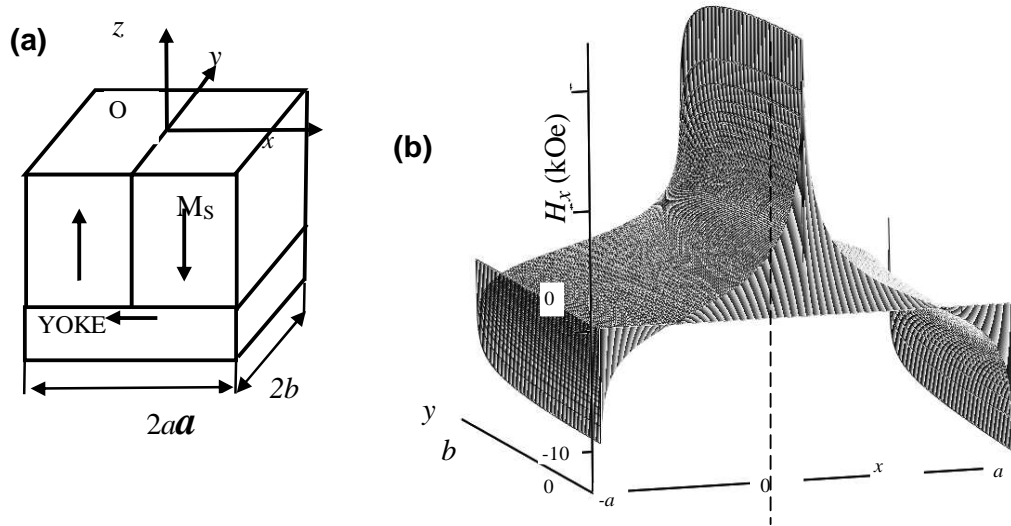

Fig. 1 (a). The system of cored magnets generating the strong magnetic field; (b) Horizontal component $H_x(x,y)$ calculated for points in the range $-a < x < a$; $0 < y < b=a/2$ on the xy -plane at $z=0.01a$. A magnet material magnetization of $M_S = 750$ G was taken for the calculations.

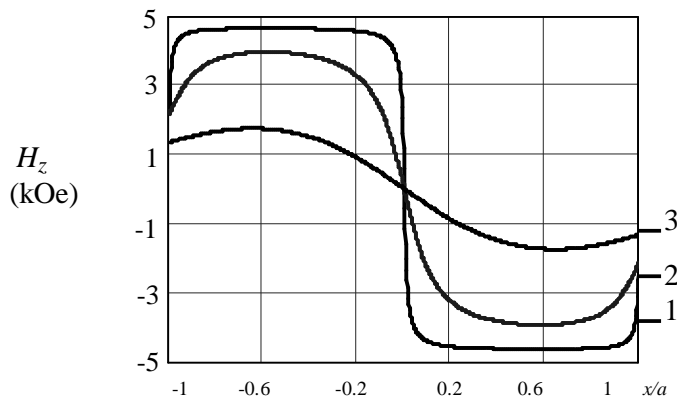

Fig. 2. Calculated vertical component of stray field $H_z(x)$ at $y = 0$ over the magnet system shown in Fig. 1a, for different distances z from the top surface: $z/a = 0.01$ – curve 1, $z/a = 0.1$ – curve 2, $z/a = 0.3$ – curve 3. $M_S = 750$ G was assumed for the calculations.

2. Experimental test system

In order to prove the existence of such fields, a system like the one in Fig. 1a was made using SmCo_5 magnets. The system had dimensions $40 \times 40 \times 10 \text{ mm}^3$. The fields were measured using a giant magnetoresistive (GMR) effect sensor of size $3 \times 1 \text{ mm}^2$ and $0.1 \mu\text{m}$ thickness [5]. From the observed data plotted in Fig. 3 it is seen that measured $H_x(x)$ is in good agreement with the fitted field profiles, which were calculated from eq. (1) assuming an M_S of 750 G for the magnet material.

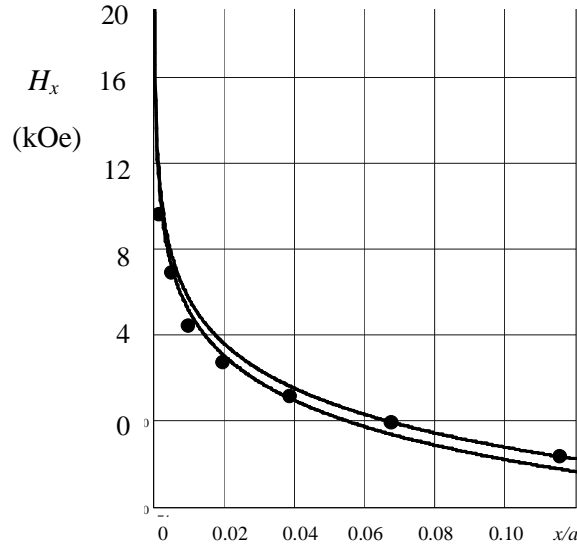

Fig. 3. Comparison of calculated (solid curves) and experimentally measured (circles) values of the stray fields above magnet system for various x/a . The upper curve corresponds to the case $b \gg a$, and the bottom one to $b = a/2$. $M_s = 750$ G was assumed.

3. Head for longitudinal recording

A novel head is constructed on the basis of the test system's ability to generate concentrated magnetic field of high strength for the component $H_x(x)$. The principal scheme of the head is shown in Fig. 4a. The head consists of a pair of magnets magnetized anti-parallel, and a system for creating the sub-magnetizing field. The magnet size in OY direction is b . A non-magnetic layer with thickness 2δ is positioned between the magnets. This layer excludes exchange interaction, and thus, stabilizes the magnetic state in the magnets. The magnet size is $c \gg a$ in the direction of the z axis. The calculated $H_x(x, y)$ component at $z = 0.01a$ is plotted in Fig. 4b. For calculations, we assumed a residual magnetization of $M = 1000$ G for the magnet material, and a layer width of $2\delta = 0.05a$. From the figure it is seen that the non-magnetic layer increases the recording area size and decreases the strength of strong field. So, this layer should be thin, satisfying the condition of $a/\delta > 100$.

The scheme of the sub-magnetization system is shown on Fig. 4a. This system is necessary to generate the sub-magnetization field of same direction, i.e., according to magnetization the recording. The sub-magnetization system should provide magnetization of adjacent soft-magnetic layers in anti-parallel of neighboring magnets. The recording is carried out as follows: the head is positioned above the medium at such distance t , that longitudinal (or perpendicular) component of permanent magnet stray field being a bit lower than the field of nucleation H_{nuc} (or coercive force H_C) of storage magnetic media. Then, sub-magnetisation system is switched on and creates an additional field ΔH with the value corresponding to resulting field $\Delta H + H_x > H_{\text{nuc}}$ (or coercive force H_C). The additional field ΔH should be high enough (1-3 kOe) to allow to optimize the recording on media with different coercive force. Additionally, the field ΔH should exceed the stray field H_0 occurring at the interface of the medium where alternation of magnetization direction in storage medium takes place (the point of 1 type, see Fig. 4a). This requirement is connected with the fact that H_0 field direction on right hand from the point 1 (Fig.4a) coincides with magnetization field of the magnets H_x . As a result, the total field $H_0 + H_x$ may become higher than H_C , and during further head movement, homogeneous medium magnetization will occur even if recorded signal is not given on the head. The possibility to set the field ΔH value in wide range permits to avoid rubbing out the information during the head movement.

It is worth noting that in the case of a film variant of the head, one should produce non-magnetic interlayer as well between soft-magnetic layers of sub-magnetization system and high-coercive magnets. Such the interlayer excludes exchange interaction between the layers and, consequently, does not lead to decreased permeability of soft magnetic layer.

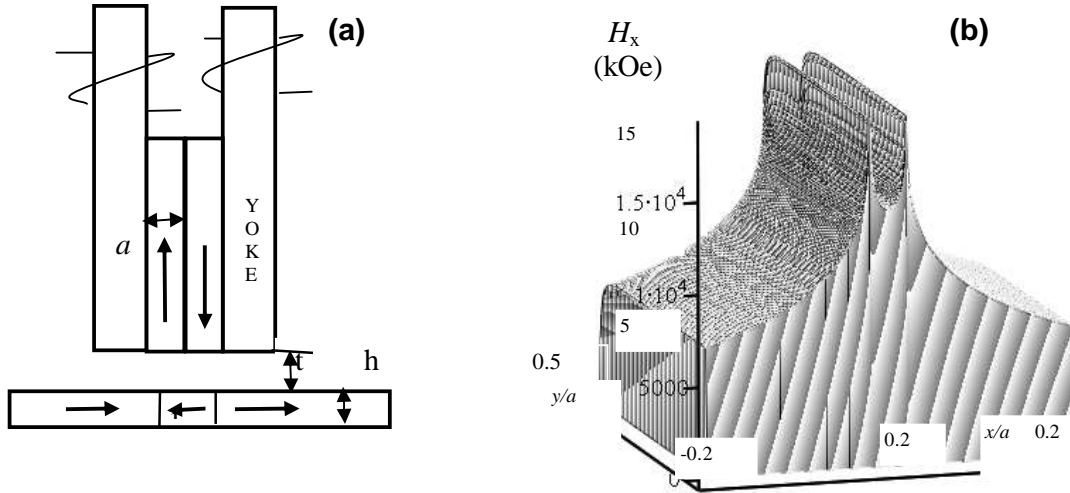

Fig. 4. (a) Scheme of the head for longitudinal recording. (b) Calculated stray field longitudinal component $H_x(x, y)$ in the area $-0.2a < x < 0.2a$, $-0.5a < y < 0$ on the plane XOY ($z = 0$). For the calculations, $M_s = 1000$ G and non-magnetic layer thickness $2\delta = 0.05a$ were taken.

It is expected that due to existence of cores in sub-magnetization system which are positioned along with the magnets, the decrease of stray fields in recording point will occur. Preliminary evaluation calculations have shown that the decrease of the field would not be substantial, if the material of hard-magnetic layer possesses the giant value of uniaxial magnetic anisotropy field. For example, at such anisotropy field as for SmCo_5 with $H_C = 300 - 450$ kOe [6], the additional stray fields from cores would be much smaller and practically do not change the magnetization direction in permanent magnets. Consequently, the strong field in recording point will be preserved, and its non-homogeneous properties will not change as well. Note, that on designing the sub-magnetization system, the decreasing effect of the magnets on core permeability should be taken into consideration.

It is seen from Fig. 1b that on the magnet edges in the points with coordinates $x = \pm a$, the field component H_x is directed opposite to H_x in the point O and reaches large values. In the head with core, in these points the component H enforces but will remain lower than in the point O. Under magnetization of cores in the moment of recording, the component H_x in O point will enforce, and vice versa, in the points $x = \pm a$, it will decrease. So, undesirable recording in these points will be absent.

The size of the remagnetisation area Δx on the medium may be estimated by

$$\Delta x = 2a \cdot \left[\exp\left\{ \frac{-H_{nuc} + \Delta H - H_0}{2M_s} \right\} - (t/a)^2 \right]^{0.5}. \quad (2)$$

H_0 being demagnetization field in this area, t is the distance from the medium to the head. Note that the nucleation field depends not only on magnetic parameters of medium material, but also on the remagnetisation area size and shape. By the magnitude, it may exceed the medium coercive force. It is seen from equation (2) that the area size depends on magnet sizes a , nucleation field H_{nuc} , sub-magnetization field ΔH , and saturation magnetization of head permanent magnets. Varying these parameters, it is possible to optimize the recording process. So, to obtain small sized area ($\Delta x < 0.1 \mu\text{m}$), one should use the media with high coercive force $H_C \approx 10$ kOe and higher. On high-coercive media, it is possible to obtain the small sized area even using the heads with rather large magnet characteristic size a . This is one of advantages of the proposal method.

It worth to be noted that at small distance from the medium $a/t \approx 100$, the normal component of stray field $H_z \approx 2\pi M_s$ takes high magnitudes as well (see Fig. 4). The field of such value is able to magnetize the medium locally in normal direction. To exclude this, one should use the media with $H_z > 2\pi M_s$. In addition, the media for longitudinal recording should have crystallographic texture with EA parallel to medium plane.

4. The head for perpendicular recording

The principle scheme of the head for perpendicular recording is shown on Fig. 5a. It is distinguish from longitudinal recording head in that the magnetizations in the permanent magnets are directed contrary to each other. Such system would be stable and not demagnetized, if magnet coercive force is higher than magnetisation of the permanent magnets, $H_C > 4\pi M_s$. So far as the component of strong force H_z occurs near the point O, for preserving the homogeneously magnetized state in the magnets it is required that their material possesses the strong field of uniaxial anisotropy $H_k > 100$ kOe. The head sub-magnetization_system consists of a core and a magnetizing coil. For excluding the exchange interaction between the magnets as well between the magnets and soft layers it is necessary to create a thin non-magnetic interlayer. Under electrical current recording, the both head cores are magnetized in the same direction and generate an additional field ΔH . There is an optimal distance to the medium t_0 (depending on characteristic sizes a , a_1 and core width b) corresponding to maximum field strength ΔH in the point of recording. Estimation calculations indicates the possibility to retain the sub-magnetization field over the medium $\Delta H = 2-3$ kOe and even higher.

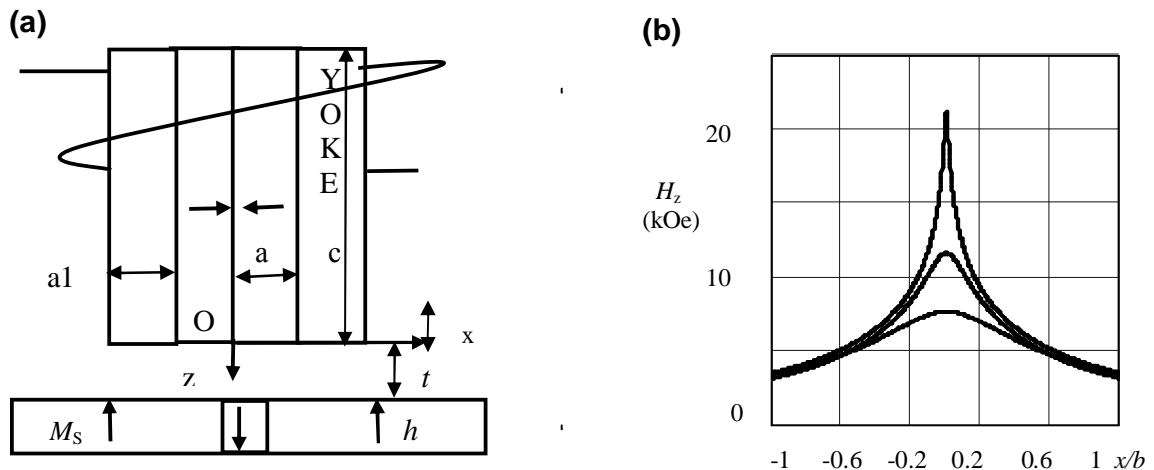

Fig. 5 (a) The scheme of the head for perpendicular recording. (b) The calculated stray field perpendicular component $H_z(x)$ for different distances from the medium; $t = 0.01b$ – the upper curve; $t = 0.1b$ – the middle curve; $t = 0.3b$ – the lower curve. For the calculations, $M_s = 1000$ G and $c = 10b$ were taken.

On Fig. 5b the calculated stray field components $H_z(x)$ over the head with sizes $c = 10b$ for different distances to the medium (the upper curve $z = 0.01b$, the middle curve $z = 0.1b$, and the lower curve $z = 0.3b$) are shown. It's worth to note, that the field strength $H_z(x)$ is determined by the magnet sizes c and b , and independent on a size.

5. Other type of the recording head

Using the strong fields occurring near the edges of charged surfaces in high-anisotropy magnets, it is possible to create other models of the heads as well. We consider only single additional model: a head for point recording. A principle scheme for perpendicular point recording without sub-magnetization system is shown on Fig. 6a. Here the OZ axis is perpendicular to XOY plane. In the vicinity of O, the component H_z takes high magnitudes, while near four points of 1 and 2 types, the strong field being caused by the component H_x . The calculated field component $H_z(x,y)$ for the points in the ranges $-0.1h < x < 0.1h$, $-0.1h < y < 0.1h$ (h – magnet thickness), is shown on Fig. 6b. For the calculations we took $M_s = 1000$ G and magnet sizes $a \gg h$. So far as for such the system, the field components H_z depend on magnet thickness h , to attain the necessary field strength magnitudes under recording, the layer thicknesses have to be more 1 μm .

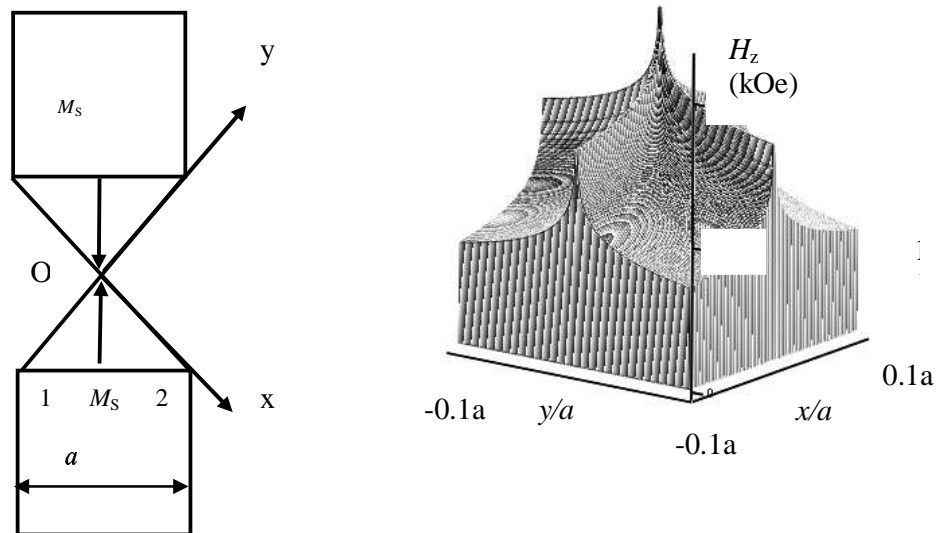

Fig. 6. The scheme of the head for point recording, a-the scheme of magnet system; b-the stray field perpendicular component $H_z(x, y)$ calculated for points in the area $-0.1a < x < 0.1a$, $-0.1a < y < 0.1a$ on the plane XOY ($z = 0$). $M_S = 1000$ G was assumed for the calculations.

6. Conclusions

The proposed system of recording on high-coercive media has a number of advantages in compared to previous ones, see e.g., [7,8]. Namely, using the proposed heads it is possible to generate strong magnetic stray fields $H_{st} > 10$ kOe with very high field gradients, up to 10 Oe/nm. Since the strong field is localized in a narrow area, it opens the path to realization of super-dense recording. However, in our opinion, for realization of such system it is necessary to resolve a number of technical tasks.

(i) First of all, it is necessary to master the technology of preparing hard-magnetic layers needed to the magnetic heads. These layers should be synthesized on the basis of rare-earth materials, because they alone may attain a uniaxial anisotropy field exceeding 100 kOe. In addition, the technology should provide the production of film layers with well defined easiest magnetization axis relative to its plane.

(ii) For creation of media for longitudinal and perpendicular recording, it is also necessary to master the technology of thin hard-magnetic layers with coercive force $H_C = 5 - 10$ kOe and higher. It would be simpler to realize the proposed recording systems, if the medium hard-magnetic layer has quite perfect magnetic and crystallographic structure. We suggest that, thin films based on Co-Pt, Co-Pd, Fe-Pt and also $BaFe_{12}O_{19}$ will be convenient as such media, since they are more stable compared to rare-earth based materials.

References

- [1] R. Wood, IEEE Trans. Magnetics **36**, 36 (2000).
- [2] H. N. Bertram and M. Williams, IEEE Trans. Magnetics **36**, 4 (2000).
- [3] H. Gavrilu, V. Ionita, J. Optoelectron. Adv. Mater. **5**(4), 919 (2003).
- [4] V. N. Samofalov, A. G. Ravlik, D. P. Belozorov, B. A. Avramenko, Phys. Metals Metallography **97**(3), (2004).
- [5] N. Jiang, K. Yamakawa, N. Honda, K. Ouchi, IEEE Trans. Magnetics **34**, 1339 (1998).
- [6] E. A. Nesbitt, J. H. Wernick, Rare Earth Permanent Magnets, Academic Press, New York (1973).
- [7] Y. Kanai, R. Matsubara, K. Fujiwara, N. Takahashi, IEEE Trans. Magnetics **38**, 2210 (2002).
- [8] K. S. Kim, C. E. Lee, S. H. Lim, IEEE Trans. Magnetics **38**, 2213 (2002).