

Trace-gas detection based on the temperature-tuning periodically poled MgO: LiNbO₃ optical parametric oscillator

J. KONG, C. C. CHAN, D. Y. TANG^a, N. NI, B. ZHAO^a

School of Chemical and Biomedical Engineering, Nanyang Technological University, Singapore 639798

^aSchool of Electrical and Electronic Engineering, Nanyang Technological University, Singapore 639798

In this paper, the possibility of using the temperature-tuned optical parametric oscillator for trace gas detection was explored. A synchronization trace gas detection system was designed and demonstrated, in which the measuring errors caused by the instability of the OPO could be greatly reduced. The trace gas detection system was based on a periodically poled MgO-doped LiNbO₃ optical parametric oscillator (OPO). The OPO was pumped by a diode-pumped passively Q-switched Nd:GdVO₄ laser which produces 3-ns laser pulse. By changing the crystal temperature and the grating periods, the OPO could produce wavelength-tunable signal output. A computer was used to synchronously measure the signal wavelength, the signal power after passing the gas cell, and the power of the reference input which is used to calculate the signal power before passing the gas cell. The usefulness of the trace gas detection system for spectroscopy was demonstrated by directly measuring the photon absorption spectrum of the methane and acetylene gas cells.

(Received April 13, 2006; accepted July 20, 2006)

Keywords: Trace-gas detection, Optical parametric oscillator, Diode-pumped, Solid-state lasers

1. Introduction

The detection of trace gases is of highly importance for many applications in the fields of environments monitoring, chemical process control, homeland security, and bio-medical research. Extremely sensitive and selective trace-gas detectors, which can identify and quantify particular trace gases at very low concentrations, are based on the laser spectroscopy [1]. It's known that each gas molecule possesses series of well-defined optical wavelengths where light is absorbed to a certain degree depending on its concentration. These absorption lines are unique for each gas, which is known as "fingerprint spectra" that can be identified. The fingerprint spectra of most organic gases, such as methane, acetylene, etc. are in the mid-infrared wavelength range of 2-5 μm which is not readily accessible with conventional laser sources. Therefore, special mid-infrared laser sources need to be developed to provide coherent radiation with the required features of wide and smooth wavelength coverage, narrow bandwidth and high average power for the laser spectroscopy purpose. Optical parametric oscillators (OPO) working in the near and mid-infrared wavelength range are a type of promising laser source for the detection of trace gases. Especially, the OPO system based on quasi-phase-matched materials has been well investigated because it can generate near and mid-infrared radiation with wide wavelength tunability and narrow line-width [2-4]. In particular, the periodically poled lithium niobate (PPLN) has attracted much attention because of its large nonlinear optical coefficient [5]. Highly efficient continuous-wave PPLN optical parametric oscillators (OPOs) have been

demonstrated and multi-watt output power is obtained [6-8]. Comparing with conventional LiNbO₃, MgO-doped LiNbO₃ is more promising to be used in the OPO systems because of the greatly improved resistance to the photorefractive damage. OPO systems based on periodically poled MgO-doped LiNbO₃ (PPMgLN) with grating tuning and temperature-tuning have been performed respectively [9-10]. In a previous paper [11], we report on the experimental results of an efficient singly resonant optical parametric oscillator based on periodically poled MgO-doped LiNbO₃. The OPO was pumped by a diode-pumped passively Q-switched Nd:GdVO₄ laser which produces 3-ns laser pulse with a repetition rate of 5 KHz. By changing the crystal temperature and grating periods, the OPO generates signal and idler output in the range of 1.41-1.78 μm and 2.7-4.3 μm respectively. The maximum output power at the signal wavelength of 1.55 μm was measured to be 35.4 mW under 120 mW absorbed pump power.

In this paper, the possibility of using the temperature-tuned optical parametric oscillator for trace gas detection was explored. A synchronization trace gas detection system based this temperature-tuned OPO was designed and demonstrated. We demonstrated that the system was so designed that the measuring errors caused by the instability of the OPO could be greatly reduced. The usefulness of the trace gas detection system for spectroscopy was demonstrated by directly measuring the photon absorption spectrum of the acetylene and methane gas cells.

2. Experimental

The trace-gas detection system in our experiment is schematically shown in Fig. 1. The diode-pumped passively Q-switched Nd:GdVO₄ laser was used as the pump source of the OPO instead of the conventional Nd:YAG laser. Comparing with the Nd:YAG laser crystal, the most important advantage of the Nd:GdVO₄ is that it can produce linearly polarized laser output under a-cut operation. Therefore, no polarization controlling components are needed in the Nd:GdVO₄ laser pumped OPO system. In addition, the emission cross-section of the Nd:GdVO₄ is much larger than that of the Nd:YAG, which is more suitable to be used in high power and compact laser system and capable to produce very narrow Q-switching laser pulses. As shown in Fig. 1, a commercial laser-diode-bar was used to pump the Nd:GdVO₄ laser. The LD pumping light was coupled to a multimode fiber with 600-micron-diameter core and focused into the Nd:GdVO₄ by two coupling lenses of 1.7 cm focal length. The focused pump beam in the laser medium had an average diameter of about 400 μm .

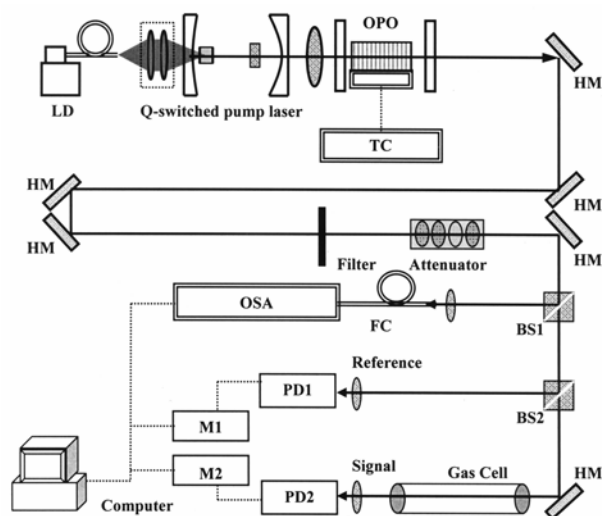

Fig. 1. Schematic of the experimental setup. HM: high reflection mirror; BS: beam splitter; FC: fiber coupler; PD: photo detector; M: digital multi-meter; TC: temperature controller.

The Nd:GdVO₄ crystal has a Nd³⁺-doping concentration of 0.5 at. %. It has a dimension of 3×3 mm in cross-section and 4 mm in length. An anti-reflection coated Cr⁴⁺:YAG crystal with an initial absorption of 60% was applied as saturable absorber. To keep the system thermally stable and prevent possible thermal fracture, both the Nd:GdVO₄ crystal and the Cr⁴⁺:YAG crystal was wrapped with indium foil and mounted in a water-cooled copper crystal holder whose temperature was controlled at

about 14 °C. With these parameters, the Q-switched laser can produce pulses as short as 3 ns and a repetition rate of 5 kHz at the wavelength of 1063 nm. The OPO was a single resonant at the signal wave and consisted of two flat mirrors, M₁ and M₂, which were separated by about 50 mm. The input mirror M₁ was a optically coated CaF₂ flat with high reflectivity for the signal wave ($R > 98\%$ at 1.5 – 1.7 μm) and idler wave ($R > 95\%$ at 2.9 – 3.5 μm) and high transmission ($T = 90\%$) at the pump wavelength; the output mirror was a coated CaF₂ flat with high reflectivity for the signal wave ($R > 95\%$ at 1.5 – 1.7 μm) and idler wave ($R > 90\%$ at 2.9 – 3.5 μm) and transmission ($T = 30\%$) at the pump wavelength. A single lens with focal length of 150 mm was used to focus the pump beam into the PPMgLN crystal, producing a waist radius of 200 μm at the center of the crystal. The multi-grating MgO-doped PPLN crystal (5 mol %) was used as nonlinear medium for the OPO. Two end faces of the crystal were antireflection coated in 1.5-1.7 μm for the signal band and 1.064 μm for the pump wavelength. The crystal was placed inside an oven with temperature stability of 0.1 °C. The optical parametric oscillation can be realized with 8 grating periods from 31.5 to 28 μm . The signal wavelength was measured by using an optical spectrum analyzer (Ando 6317) with a resolution of 0.05 nm. With different grating periods and operation temperature, the signal and idler output can be tuned in the range of 1.41-1.78 μm and 2.7-4.3 μm respectively. Fig. 2 shows the temperature-tuning curves of the OPO.

3. Results and discussion

Although the OPO can be tuned from 1.4 μm to 1.76 μm in the signal wavelength and 2.7-4.3 μm in the idler wavelength, it is far from practical application for spectroscopy. Two problems need to be solved before it is used for trace gas detection. Due to the intrinsic instability of the passively Q-switched laser, the pump power of the OPO was not stable with the time. Correspondingly the OPO output power fluctuated with time. In addition, neither the pump laser cavity nor the OPO cavity contained any etalons to control the wavelength performance. The line-width of the signal wavelength was up to 0.5 nm and mode-hopping always occurred in the system. To conquer these problems, a synchronization measuring system was designed and shown in Fig. 1, in which the signal wavelength, reference power and absorbed signal output power could be measured at the same moment. As shown in Fig.1, a filter was used to block the pump light and idler wave and pass the signal wave. The signal wave was sampled in a beam sampler (BS1) to the optical spectrum meter (OSA). A beam splitter (BS2) separated the signal wave into two parts. Part 1 was detected by photo detector 1 (PD1) directly which served as the reference input. PD2 detected the

absorbed signal power after passing through a gas cell. The signal and reference input was collected by two focal lenses and coupled to the photo detectors respectively. The signal and reference power were measured with two digital multimeters respectively. A computer was used to control the digital multimeters and the OSA. By changing the crystal temperature through the temperature controller, the OPO could produce tunable signal output. At the same time, the computer controlled the digital multimeters and the OSA to read the data at the same time point with a certain time interval.

We assumed the incident average power before passing BS2 is $P(\lambda)$ which is a function of wavelength λ . The reference power going to PD1 is $P_R(\lambda)$ and the input power to the gas cell is $P_{in}(\lambda)$. The signal power after the absorption of the gas cell is $P_{out}(\lambda)$. The absorption coefficient of the gas cell can be expressed as

$$a(\lambda) = \frac{P_{out}(\lambda)}{P_{in}(\lambda)} \quad (1)$$

Since the reflectivity of BS2 can be accurately measured, the signal power of Part 2 before passing the gas cell could be calculated according to the measured reference light power. By assuming the ratio of the input power $P_{in}(\lambda)$ to the reference $P_R(\lambda)$ is $R_0(\lambda)$, we have

$$a(\lambda) = \frac{P_{out}(\lambda)}{P_R(\lambda)R_0(\lambda)} = \frac{R_e(\lambda)}{R_0(\lambda)} \quad (2)$$

where

$$R_e(\lambda) = \frac{P_{out}(\lambda)}{P_R(\lambda)} \quad (3)$$

From equation (2) one can see that to obtain the absorption coefficient, the most important is to get the ration of the output power to reference power. Therefore, if one can measure the reference power $P_R(\lambda)$ and the signal power $P_{out}(\lambda)$ at the same time, the effect caused by the fluctuation of the signal output power will be eliminated. Similar, since the signal wavelength was also measured at the same time with the light power, the effect caused by the mode hopping of the OPO can be reduced. It is worth to note that because of two limitations, the effect caused by the wavelength mode-hopping cannot be fully eliminated. Firstly, as previously discussed, an OSA was used to measure the wavelength of the input signal. Since the scanning time of the OSA is around 1 second which is comparable with the mode-hopping rate, the measured results are actually averaged. Secondly, the line width of the signal wavelength is not narrow enough, which has greatly limited the resolution of the system.

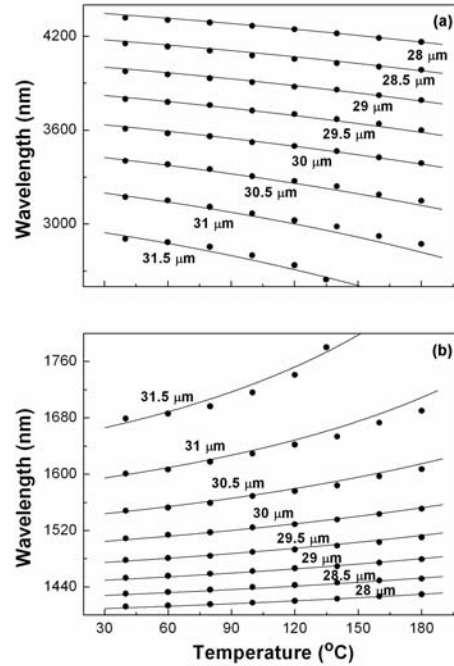

Fig. 2. Temperature tuning curves for 1.064- μm -pumped OPO in PPMgLN with different grating periods: (a) idler wavelength; (b) signal wavelength. Filled circles: experimental data; solid curves: theoretical fitting curves.

After obtaining the tunable output of the OPO, the acetylene gas cell was put in the system and its absorption spectrum at 1527-1537 nm was measured. To tune the OPO output wavelength from 1527 nm to 1537 nm, the PPMgLN crystal temperature need to be increased from 110 °C to 138 °C respectively. It is worth to mention that if the crystal temperature increased too fast, the OPO output wavelength may hop from one wavelength to another and miss the absorption line of the acetylene. Therefore, the temperature must be increased as slow as possible. On the other hand, if the crystal temperature keeps staying at one point, the averaging effect will become prominent because of the randomly mode-hopping of the OPO wavelength around certain central wavelength which is determined by the crystal temperature. To avoid this problem, one must depress the mode hopping of the OPO by inserting an etalon in the cavity, which will be further investigated as the next step of the experiment. Fig. 3 shows the measured absorption spectrum of the acetylene. The background spectrum was shown in Fig. 3.a. It was measured when there was no gas cell was put in the system and only determined by the reflectivity of BS2. The absorption spectrum of the methane gas cell was measured and shown in Fig. 3.b to Fig. 3.c in decibel and with different temperature increasing rate. It is shown clearly that slower temperature increasing rate can lead to more prominent absorption. The actual value of the absorption coefficient can be derived by directly subtracting the background spectrum shown in Fig. 3.a. On the other hand, since the line width of the signal

wavelength is much wider than the absorption line of the methane, the fine structure of the absorption spectrum cannot be observed in this figure.

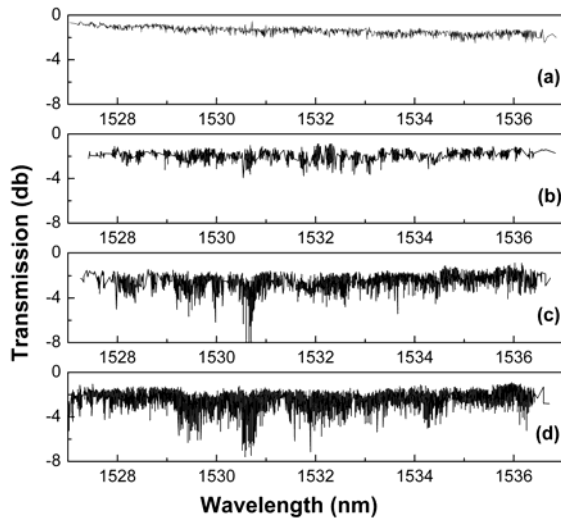

Fig. 3. The ratio of the input power to the reference power as a function of the wavelength with acetylene gas cell.

The absorption spectrum of the methane was also measured. The background absorption $R_0(\lambda)$ at 1640-1690 nm was firstly measured as shown in Fig. 4. With 50-nm scanning range, the reflectivity of BS2 has greatly changed. Therefore, the background of the absorption spectrum is bended up toward long-wavelength direction. By subtracting the background from the spectrum, the actual absorption spectrum of the methane was derived as shown in Fig. 5.

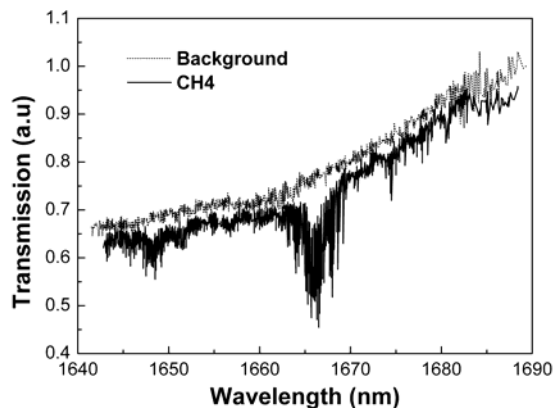

Fig. 4. The ratio of the input power to the reference power as a function of the wavelength with methane gas cell.

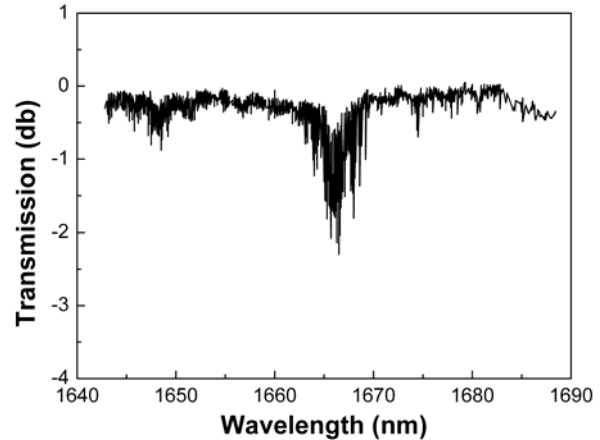

Fig. 5. The absorption spectrum of the methane at 1640-1690 nm.

As previously discussed, the system was mainly limited by the resolution of the OSA and the instability of the signal wavelength. Correspondingly, to further improve the system performance, the line width of the OPO output wavelength should be compressed as well as the resolution of the wavelength measurement device needs to be enhanced. As the next step, we will try to reduce the OPO line width by inserting the etalon in the OPO and pump laser cavity. In addition, the monochromator will replace the optical spectrum analyzer to measure the wavelength, which can provide much higher wavelength resolution and more rapid response time.

4. Conclusions

The possibility of using the temperature-tuned optical parametric oscillator for trace gas detection was explored. A synchronization trace gas detection system was designed and demonstrated. We have demonstrated an efficient compact singly resonant optical parametric oscillator (OPO) based on periodically poled MgO-doped LiNbO₃. A diode-pumped passively Q-switched Nd:GdVO₄ laser was used as the pump source, which can produce 3-ns linearly polarized laser pulse with a repetition rate of 5 KHz. By changing the crystal temperature and grating periods, the OPO generates signal and idler output in the range of 1.41-1.78 μm and 2.7-4.3 μm respectively. The maximum output power was measured to be 35.4 mW with a 120 mW pump power at the signal wavelength of 1.55 μm . The absorption spectra of methane and acetylene were measured by using this system. The preliminary results show that the temperature-tuning OPO system based on PPMgLN and pumped by Nd:GdVO₄ laser has great potential for the trace gas detection.

References

- [1] R. F. Curl, F. K. Tittel, "Tunable infrared laser spectroscopy", *Annu. Rep. Prog. Chem., Sect. C* **98**, 219 (2002).
- [2] K. A. Tillman, R. R. J. Maier, D. T. Reid, E. D. McNaghten, "Mid-infrared absorption spectroscopy of methane using a broadband femtosecond optical parametric oscillator based on aperiodically poled lithium niobate", *J. Opt. A: Pure Appl. Opt.* **7**, S408 (2005).
- [3] A. Popp, F. Müller, F. Kühnemann, S. Schiller, G. von Basum, H. Dahnke, P. Hering, M. Mürtz, "Ultra-sensitive mid-infrared cavity leak-out spectroscopy using a cw optical parametric oscillator", *Appl. Phys. B* **75**, 751 (2002).
- [4] K. W. Anioleka, P. E. Powersb, T. J. Kulp, B. A. Richmana, S. E. Bisson, "Cavity ringdown laser absorption spectroscopy with a 1 kHz mid-infrared periodically poled lithium niobate optical parametric generator/optical parametric amplifier", *Chem. Phys. Lett.* **302**, 555 (1999).
- [5] L. E. Myers, R. C. Eckardt, M. M. Fejer, R. L. Byer, W. R. Bosenberg, J. W. Pierce, "Quasi-phase-matched optical parametric oscillators in bulk periodically poled LiNbO₃", *J. Opt. Soc. Am. B* **12**, 2102 (1995).
- [6] M. van Herpen, S. te Lintel Hekkert, S. E. Bisson, and F. J. M. Harren, "Wide single-mode tuning of a 3.0–3.8- μm , 700-mW continuous-wave Nd:YAG-pumped optical parametric oscillator based on periodically poled lithium niobate", *Opt. Lett.* **27**, 640 (2002).
- [7] M. M. J. W. van Herpen, S. Li, S. E. Bisson, S. te Lintel Hekkert, F. J. M. Harren, "Tuning and stability of a continuous-wave mid-infrared high-power single resonant optical parametric oscillator", *Appl. Phys. B* **75**, 329 (2002).
- [8] M. M. J. W. van Herpen, S. E. Bisson, A. K. Y. Ngai, F. J. M. Harren, "Combined wide pump tuning and high power of a continuous-wave, singly resonant optical parametric oscillator", *Appl. Phys. B* **78**, 281 (2004).
- [9] D. Y. Shen, S. C. Tam, Y. L. Lam, T. Kobayashi, "Singly resonant optical parametric oscillator based on periodically poled MgO:LiNbO₃", *Electron. Lett.* **36**, 1488 (2000).
- [10] H. P. Li, D. Y. Tang, S. P. Ng, J. Kong, "Temperature-tunable nanosecond optical parametric oscillator based on periodically poled MgO:LiNbO₃", *Opt. Laser Technology* **38**, 192 (2006).
- [11] J. Kong, C. C. Chan, N. Ni, B. Zhao, D. Y. Tang, "Temperature-tuning optical parametric oscillator based on periodically poled MgO:LiNbO₃", *Opt. Eng.* (submitted).

* Corresponding author: jkong@ntu.edu.sg.